



LABORATORY MANUAL (ME- 215-F MATERIAL SCIENCE LAB)

Sessional: 25 Marks

L T P

Practical Examination : 25 Marks

- - 2

Total : 50 Marks

List of Experiments:

1. To study crystal structures of a given specimen.
2. To study crystal imperfections in a given specimen.
3. To study Bravais lattices with the help of models.
4. To prepare solidification curve for a given specimen.
5. To study heat treatment processes (hardening and tempering) of steel specimen.
6. To study microstructures of metals/ alloys.
7. To study thermo-setting of plastics.
8. To study the creep behavior of a given specimen.
9. To study the mechanism of chemical corrosion and its protection.
10. To study microstructure of heat-treated steel.
11. To study the properties of various types of plastics.
12. To study crystal structures and crystals imperfections using ball models.

Note:-

1. At least ten experiments are to be performed in the semester.
2. At least eight experiments should be performed from the above list.

Remaining two experiments may either be performed from the above list or designed & set by the concerned institute as per the scope of the syllabus.

EXPERIMENT NO. 1

OBJECTIVE: TO STUDY THE CRYSTAL STRUCTURE OF A GIVEN SPECIMEN.

THEORY:-

BCC:-

In body centered cubic structure each one atom is placed at the corner of the cube and one atom is placed at the centre of the cube. Iron has BCC structure. At room temperature the unit cell of iron has an atom at each corner and another at the body centre of the cube. Each iron atom in BCC structure is surrounded by eight adjacent iron atoms. The unit cell of a cubic cell contains eight atoms at corners which are shared by the adjoining eight cubes.

Hence the share of each cube = $\frac{1}{8}$ of each corner atoms

Total no of atoms = $\frac{1}{8} \times 8 = 1$ atom

BCC crystal has one atom at center.

So, total no. of atoms in BCC = 2 atoms

FCC:-

In this type of structure the unit cell contains one atom at center of each corner plus at each face. Examples of such type of crystal structure are copper, silver, gold etc. In FCC crystal the atom on each face is surrounded or shared by two cubes. So contribution of each towards crystal is $\frac{1}{2}$, one atom at each corner. i.e. shared by eight other cubes so that its contribution towards crystal is $\frac{1}{8}$.

So total no of atoms = $\frac{1}{8} \times 8 + \frac{1}{2} \times 6 = 4$ atoms

HCP:-

In case of hexagonal closed packing structure there are 12 atoms at corner. One atom at the center of two hexagonal faces and three atoms symmetrically arranged in the body of unit cell.

Total no of atoms per unit cell = $\frac{1}{6} \times 6 + \frac{1}{6} \times 6 + \frac{1}{2} \times 2 + 3 = 6$ atoms

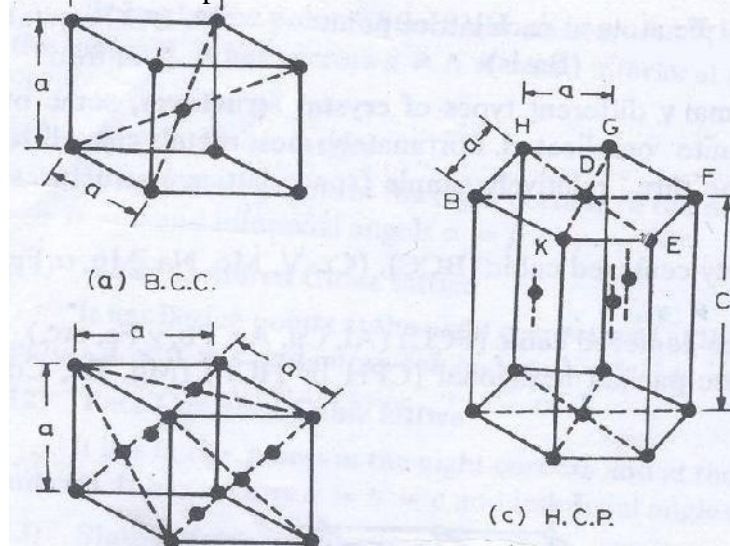

ATOMIC RADIUS:-

It is defined as half the distance between the nearest neighbors in the crystal structure of a pure element. It is expressed in terms of the cube edge element a and denoted by r .

BCC:-

In this structure, the atoms touch each corner along the diagonal of the cube.

So,

$$AB^2 = a^2 + a^2$$

$$AB^2 = 2a^2$$

$$(AC^2) = (AB^2) + (BC^2)$$

$$(AC^2) = 2a^2 + a^2$$

$$4r = \sqrt{3} a^2$$

$$r = \sqrt{3}/4a$$

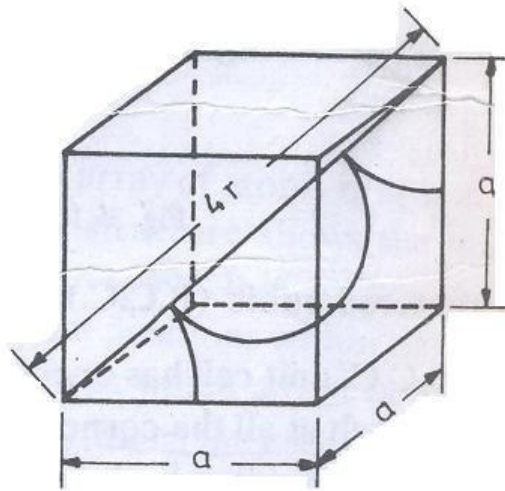
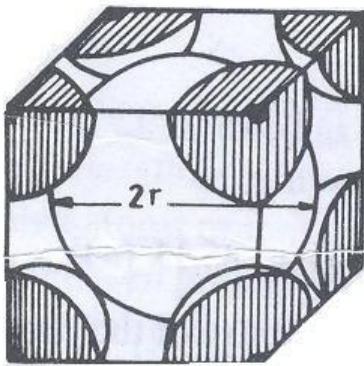

FCC:-

In this structure, one atom at each eight corners in addition to one atom at each face is present. From the geometry of the fig.

$$BD = 4r = \sqrt{a^2 + a^2}$$

$$4r = \sqrt{2} a$$

$$R = \sqrt{2}/4 \times a$$

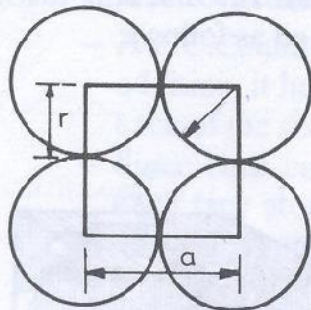

(a)

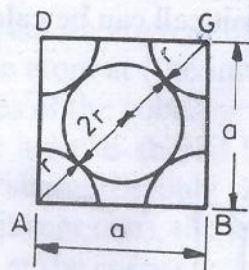

(b)

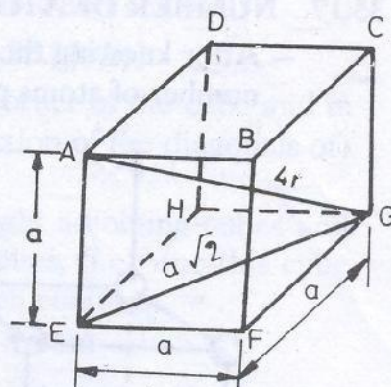

(c)

ATOMIC PACKING FACTOR:-

It may be defined as the fraction of volume occupied by spherical atoms as compared to the total available volume of the structure.

$$\text{A.P.F.} = \frac{\text{volume of atoms in a crystal}}{\text{volume of unit cell}} = \frac{H}{V}$$

FOR BCC CRYSTAL:-

Atoms per unit cell = 2

$$\text{Volume} = 2 \times \frac{4}{3} \pi r^3$$

$$V = 2 \times \frac{4}{3} \pi \times \left(\frac{\sqrt{3}}{4} \times a\right)^3$$

$$\text{APF} = \frac{2 \times \frac{4}{3} \pi r^3}{\left(\frac{4r\sqrt{3}}{1}\right)^3}$$

$$= 0.68$$

Atomic packing factor for BCC crystal is 0.68.

FOR FCC:-

Total no of atoms = 4

$$\text{Volume of 4 atoms} = \frac{4 \times \frac{4}{3} \pi r^3}{3}$$

$$\text{APF} = \frac{4 \times \frac{4}{3} \pi r^3}{(2\sqrt{2}r)^3}$$

$$= 0.74$$

Atomic packing factor for FCC crystal is 0.74.

EXPERIMENT NO. 2

OBJECTIVE: - TO STUDY THE IMPERFECTION IN CRYSTAL.

THEORY:-

Any deviation from completely ordered arrangement in a crystal constitutes a disorder. The crystal may have additional defects due to the presence of same impurities.

TYPES OF DEFECTS:-

(A) POINT DEFECT:-

- (i) Vacancy
- (ii) Interstitialcies
- (iii) Impurities
- (iv) Electronic Defect

(i) Vacancy:-

It is a vacant place in crystal due to missing of a regular atom or parent atom from the regular atomic site.

(ii) Interstitialcies :-

An interstitial defect arises when an atom occupies a definite position in the lattice that is not normally occupied in the perfect crystal.

(iii) Impurities :-

Impurity atoms are introduced in crystal structure as substitutional or interstitial atoms, i.e. foreign atoms either occupy lattice sites from which the regular atom are missing or they occupy positions between the atoms of the ideal crystal.

(iv) Electronic Defect:

Electronics defects are the result of errors in charge distribution in solids. These defects are free to move in the crystal under the influence of an electric field

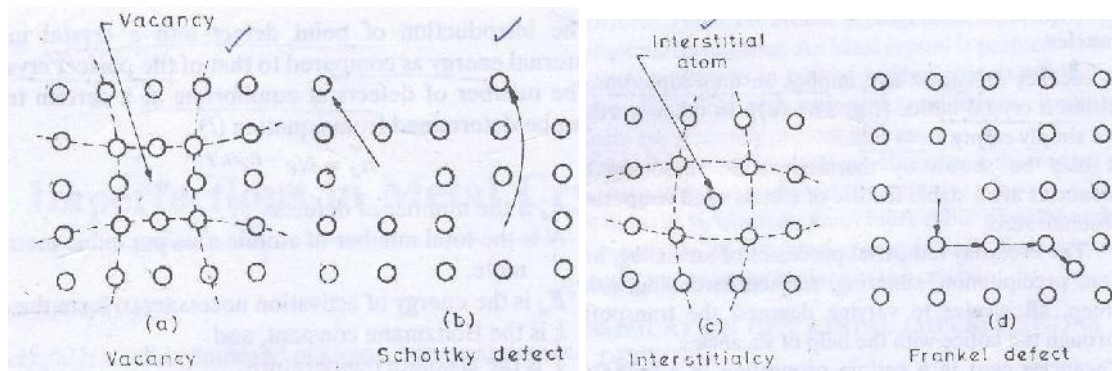

(B) LINE DEFECT:-

The most important two dimensional or line defect is the dislocation. A dislocation may be defined as a disturbed region between two subsequently perfect parts of a crystal

The two basic types of dislocation are:

- (1) Edge dislocation
- (2) Screw dislocation

(1) Edge dislocation:-

Edge dislocation is produced due to introduction of an extra row of atoms. Dislocation is along an edge inside a crystal.

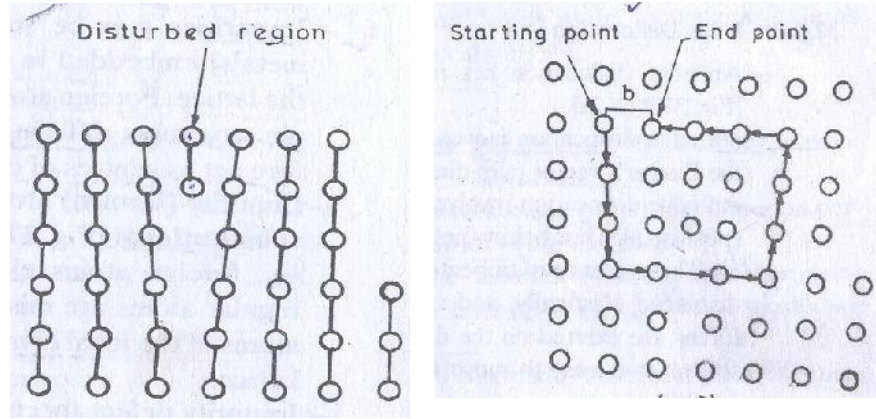

Edge Dislocation

(2) Screw dislocation:-

It is produced because of the partial slipping of a section of crystal plane additional atoms and unit cells are added to stop of the screw. In this only shear stress field exists.

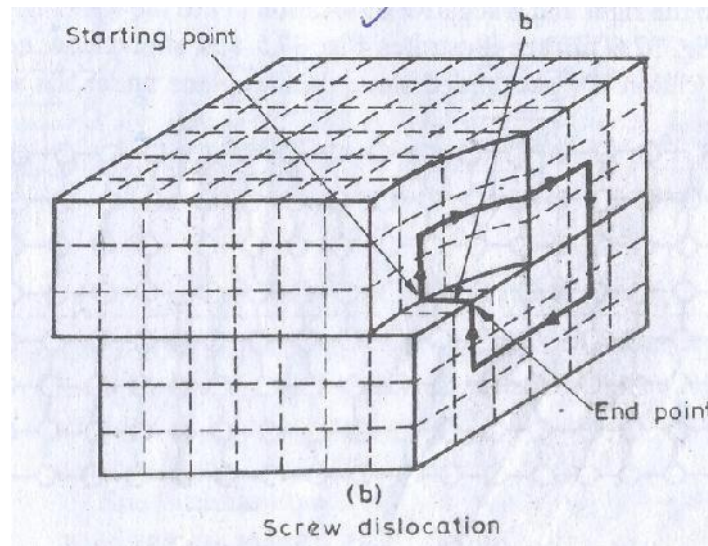

(C) SURFACE DEFECTS:-

These defects take place on the surface of the material. They are of three types:-

- (1) Grain boundaries
- (2) Tilt boundary
- (3) Twin Boundary

(1) Grain boundary:-

During solidification of molten metal grains of different orientations separate the general patterns of atom and exhibits a boundary. Then the defect caused is known as grain boundary defect.

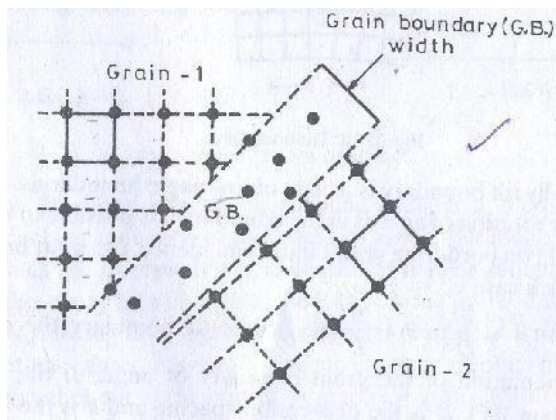

Grain Boundary

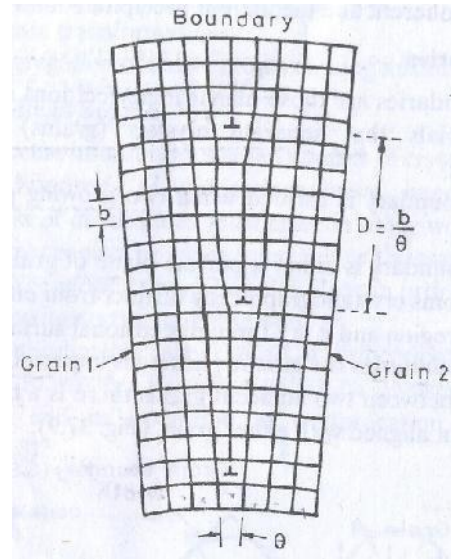

Tilt Boundary

(2) Tilt boundary:-

Tilt boundary is another surface imperfection, and it may be regarded as an array of edge dislocation. By rotation of an axis in the boundary it is possible to bring the axis of two bordering grain into coincidence, i.e., a tilt boundary,

(3) Twin Boundary:-

Here the boundary in which the atomic arrangement on one side of the boundary is a mirror image of the arrangement of atom on the other side

(D) VOLUME DEFECT:-

Volume defect is mainly due to the presence of foreign particles inclusion (large voids) or non-crystalline region in the crystal. Due to the presence of such particles, the physical and mechanical properties of the crystal affect.

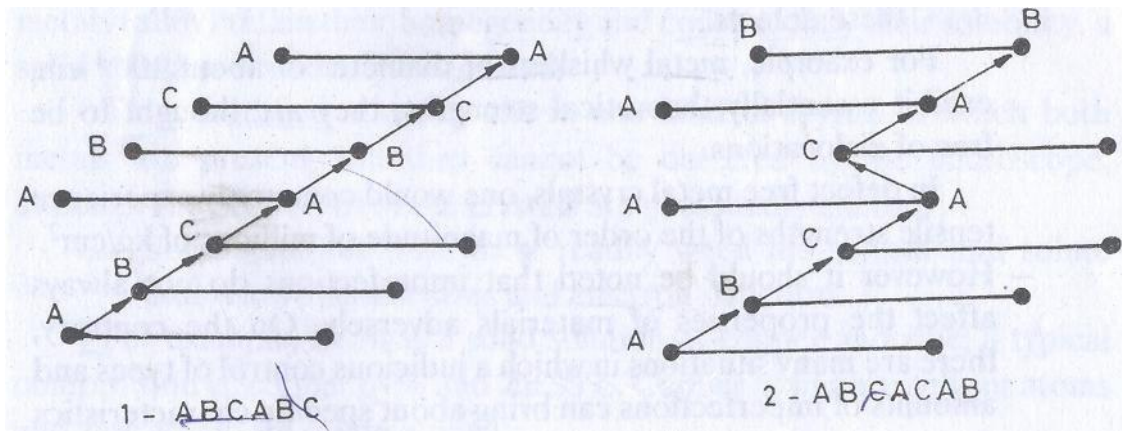

Volume Defects

EXPERIMENT NO. -3

OBJECTIVE: To study Bravais lattices with the help of models.

Theory:

Bravais lattices named after their originator Mr. Bravais, are the 14 distinguishable three dimensional space lattices that can be generated by repeated translation of three non coplanar vectors a , b and c of a unit cell in three dimensional space. Seven sets of axis are needed to construct the fourteen Bravais lattice. Accordingly, all crystalline solids can be classified into 7 crystal systems.

(1) Simple Monoclinic Lattice:-

It has lattice points at the eight corners of the unit cell. It has vectors $a \neq b \neq c$ and interaxial angles $\alpha = \gamma = 90^\circ \neq \beta$, (the crystal system).

(2) End Centered Monoclinic Lattice:-

It has lattice points at the eight corners and at two face centers opposite to each other. It has vectors $a \neq b \neq c$ and interaxial angles $a \neq b \neq c$, and interaxial angles $\alpha = \beta = 90^\circ \neq \gamma$.

(3) Triclinic Lattice:-

It has lattice points at the eight corners of the unit cell. It has vectors $a \neq b \neq c$ and interaxial angles $\alpha \neq \beta \neq \gamma \neq 90^\circ$.

(4) Hexagonal Lattice:

It has points at the twelve corners of the hexagonal prism and at the centers of the two hexagonal faces of the unit cell. It has vectors $a = b \neq c$ and interaxial angles $\alpha = \beta = 90^\circ$ and $\gamma = 120^\circ$.

(5) Rhombohedral Lattice:

It has lattice points at the eight corners of the unit cell. It has vectors $a = b = c$ and interaxial angles $\alpha = \beta = \gamma \neq 90^\circ$.

(6) Simple Orthorhombic Lattice:

It has lattice points at the eight corners of the unit cell. It has vectors $a \neq b \neq c$ and interaxial angles $\alpha = \beta = \gamma = 90^\circ$.

(7) Body Centered Orthorhombic Lattice:

It has lattice points at the eight corners and at the body centre. It has vectors $a \neq b \neq c$ and interaxial angles $\alpha = \beta = \gamma = 90^\circ$.

(8) End Centered Orthorhombic Lattice:

It has lattice points at the eight corners and at two face centers opposite to each other. It has vectors $a \neq b \neq c$ and interaxial angles $\alpha = \beta = \gamma = 90^\circ$.

(9) Face Centered Orthorhombic Lattice:

It has lattice points at the eight corners and at the six face centers of the unit cell. It has vectors $a \neq b \neq c$ and interaxial angles $\alpha = \beta = \gamma = 90^\circ$.

(10) Simple Cubic Lattice:

It has lattice points at the eight corners of the unit cell. It has vectors $a = b = c$ and interaxial angles $\alpha = \beta = \gamma = 90^\circ$.

(11) Body Centered Cubic Lattice:

It has lattice points at the eight corners and at the body centre. It has vectors $a = b = c$ and interaxial angles $\alpha = \beta = \gamma = 90^\circ$.

(12) Face Centered Cubic Lattice:



It has lattice points at the eight corners and at the face centers of the unit cell. It has vectors $a = b = c$ and interaxial angles $\alpha = \beta = \gamma = 90^\circ$.

(13) Simple Tetragonal Lattice:-

It has lattice points at the eight corners of the unit cell. It has vectors $a = b \neq c$ and interaxial angles $\alpha = \beta = \gamma = 90^\circ$.

(14) Body Centered Tetragonal Lattice:-

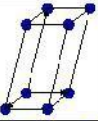
It has lattice points at the eight corners and at the body centre. It has vectors $a = b \neq c$ and interaxial angles $\alpha = \beta = \gamma = 90^\circ$.

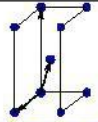
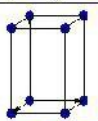
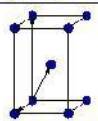
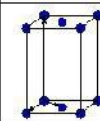
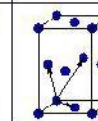
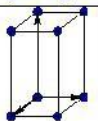
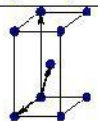
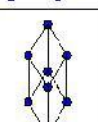
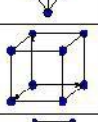
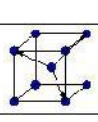
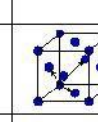
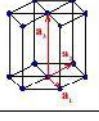
Bravais lattice	Parameters	Simple (P)	Volume centered (I)	Base centered (C)	Face centered (F)
Triclinic	$a_1 \neq a_2 \neq a_3$ $\alpha_{12} \neq \alpha_{23} \neq \alpha_{31}$				
Monoclinic	$a_1 \neq a_2 \neq a_3$ $\alpha_{23} = \alpha_{31} = 90^\circ$ $\alpha_{12} \neq 90^\circ$				
Orthorhombic	$a_1 \neq a_2 \neq a_3$ $\alpha_{12} = \alpha_{23} = \alpha_{31} = 90^\circ$				
Tetragonal	$a_1 = a_2 \neq a_3$ $\alpha_{12} = \alpha_{23} = \alpha_{31} = 90^\circ$				
Trigonal	$a_1 = a_2 = a_3$ $\alpha_{12} = \alpha_{23} = \alpha_{31} < 120^\circ$				
Cubic	$a_1 = a_2 = a_3$ $\alpha_{12} = \alpha_{23} = \alpha_{31} = 90^\circ$				
Hexagonal	$a_1 = a_2 \neq a_3$ $\alpha_{12} = 120^\circ$ $\alpha_{23} = \alpha_{31} = 90^\circ$				

EXPERIMENT NO 4

OBJECTIVE: TO STUDY THE SOLIDIFICATION CURVE OF GIVEN METAL.

THEORY:-

Solidification in pure metals and eutectic alloys takes place at constant temperature. In solid solution alloys proceed over a temperature range. Solidification occurs by the nucleation of very small crystals which grow under the thermal and crystallographic conditions existing during solidification. A metal in molten condition has high energy, as the metal cools; it loses energy to form crystal. Since heat loss is more rapid near mold walls than any other place, the first submicroscopic metal crystallites called nuclei from pure metal experience difficulty in starting to crystallize if no nuclei in form of impurities are present to start the crystallization.

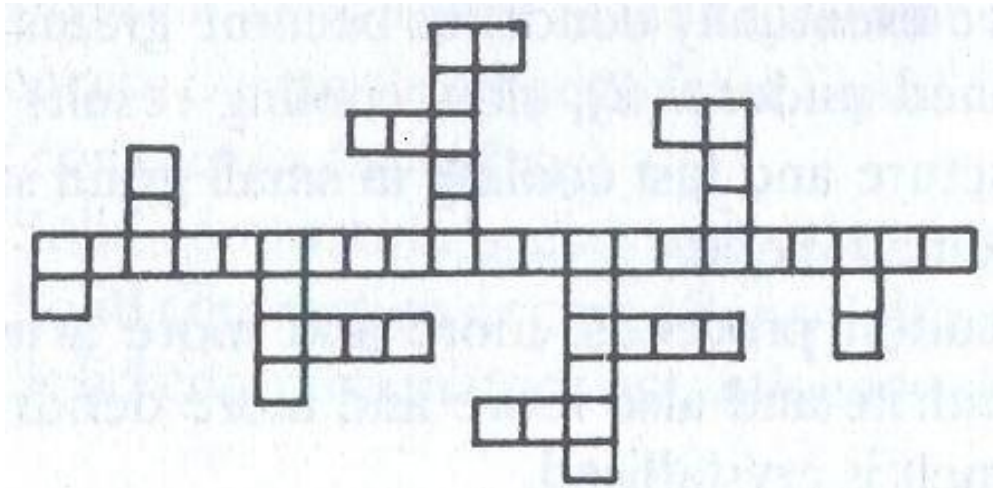

Pure metals generally possess excellent thermal and electrical conductivity, higher melting points, lower yields point and tensile strength. Because of their higher melting points, [pure metals exhibit certain difficulties in casting i.e.

- (1) Difficulties during pouring
- (2) Occurrence of server metal mould reactions.
- (3) Greater tendency towards cracking.
- (4) Their mode of solidification, which may produce defective casting.

Pure metals melts and solidify to as single temperature which may be termed as melting point or freezing point. Above freezing point the metal is liquid and below freezing point it is in solid state. While the pour metal is cooled under equilibrium conditions from the molten state till it solidify, a time temperature will look in figure.

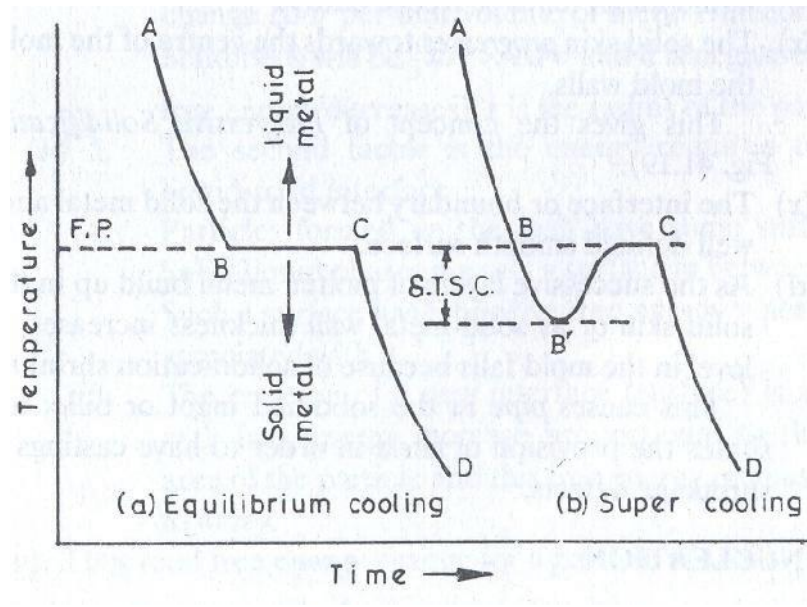

Liquid metal cools from A to B.

From B to C the metal liberates.

Latent heat of fusion and temperature remains constant. The liquid metal starts solidifying at B and it is partially liquid and partially solid at any point Between B and C, and at C the metal is purely solid. From C to D, the solid metals cool and tend to reach at room temperature. As the successive layers of molten metal build up in the form in solid skin as solid metal wall thickness increases.

EXPERIMENT NO:- 5

OBJECTIVE:- TO STUDY HEAT TREATMENT PROCESSES (ANNEALING & TEMPERING) APPLIED TO A GIVEN SPECIMEN.

THEORY:

HARDENING of steels is done to increase the strength and wear properties. One of the prerequisites for hardening is sufficient carbon and alloy content. If there is sufficient Carbon content then the steel can be directly hardened. Otherwise the surface of the part has to be Carbon enriched using some diffusion treatment hardening techniques. Hardening is performed to impart strength and hardness to alloys by heating up to a certain temperature, depending on the material, and cooling it rapidly. Steel is heated and held there until its carbon is dissolved, and then cooled rapidly. Quenching is performed to cool hot metal rapidly by immersing it in brine (salt water), water, oil, molten salt, air or gas. Quenching sets up residual stresses in the work piece and sometimes results in cracks. Residual stresses are removed by another process called annealing.

Stages of hardening

Stage 1 Heating: Steel with sufficient carbon (0.35-0.70%) is heated to a suitable temperature.

Stage 2 Soaking: The specimen is held at that temperature from 15 to 30 minutes per 25 mm of cross section.

Stage 3 Cooling: The specimen is cooled rapidly or quenched in a suitable medium brine, water, oil etc.

TEMPERING is a process done subsequent to quench hardening. Quench-hardened parts are often too brittle. This brittleness is caused by a predominance of Martensite. This brittleness is removed by tempering. Tempering results in a desired combination of hardness, ductility, toughness, strength, and structural stability.

The mechanism of tempering depends on the steel and the tempering temperature. The prevalent Martensite is a somewhat unstable structure. When heated, the Carbon atoms diffuse from Martensite to Cementite, which is the stable form.

Tempering is done immediately after quench hardening. When the steel cools to about 40 °C (104 °F) after quenching, it is ready to be tempered. The part is reheated to a temperature of 150 to 400 °C (302 to 752 °F). In this region a softer and tougher structure Troostite is formed. Alternatively, the steel can be heated to a temperature of 400 to 700 °C (752 to 1292 °F) that

results in a softer structure known as Sorbite. This has less strength than Troostite but more ductility and toughness.

After the hardening treatment is applied, steel is often harder than needed and is too brittle for most practical uses. Also, severe internal stresses are set up during the rapid cooling from the hardening temperature. To relieve the internal stresses and reduce brittleness, tempering should be done to reduce hardness.

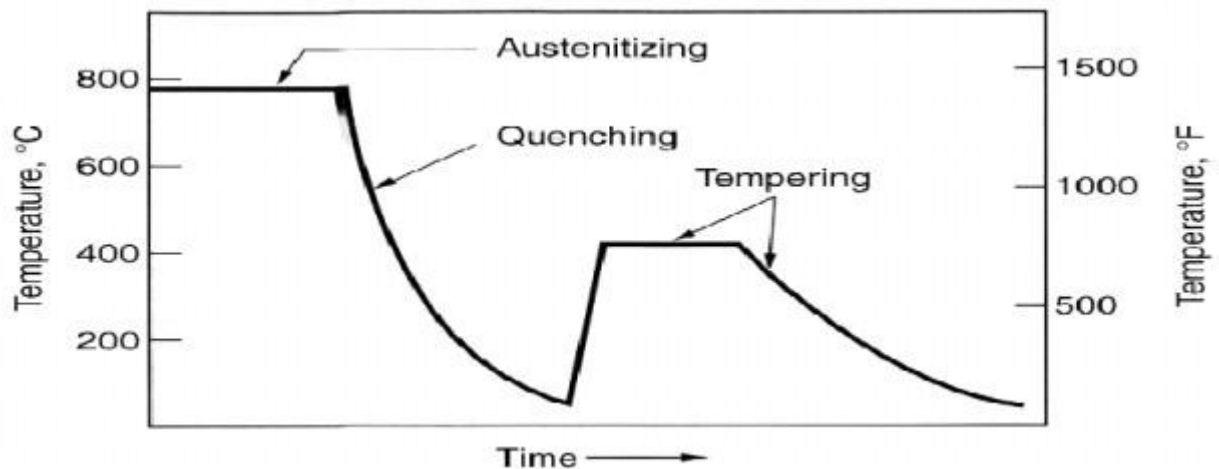

Tempering consists of heating the steel to a specific temperature (below its hardening temperature), holding it at that temperature for the required length of time, and then cooling it, usually in still air. The resultant strength, hardness, and ductility depend on the temperature to which the steel is heated during the tempering process.

The purpose of tempering is to reduce the brittleness imparted by hardening and to produce definite physical properties within the steel. Tempering always follows, never precedes, the hardening operation.

Tempering is always conducted at temperatures below the low-critical point of the steel. In this respect, tempering differs from annealing, normalizing, and hardening in which the temperatures are above the upper critical point.

EXPERIMENT NO. 6

OBJECTIVE:-TO STUDY THE MICROSTRUCTURE OF MILD STEEL WITH THE HELP OF MICROSCOPE.

APPARATUS:-

Microscope, specimen mounting press, mild steel specimen, bakelite powder, polishing machine, emery paper, emery cloth, alumina powder of different grades.

THEORY:-

Study of microstructure:-

Metallurgy is a science of evaluating metal structure and is an important field of metallurgy. The metallurgy grapher must prepare the specimen to obtain a true image of structure and then exactly evaluate. Structure examination and study of microstructure of specimen is regarded to determine metallurgical effect of heat treatment and manufacturing process etc.

Trained metallographers are able to evaluate microscopic appearance of metals so that advice ability of particular metallurgical method can be predicted. Many photo micrographs and sketches of metallic structure are included in book because all metallurgical processes have definite effects on the metallurgical nature of process and these processes can be studied in terms of these metallurgical effects.

DEVELOPMENT OF METALLOGRAPHY:-

Many new techniques have been developed over last decade that extend significantly the metallographers ability to investigate the micro structural analysis. Micro structural analysis is science of revealing and evaluating internal structure of materials as usually involves polishing of specimen, etching surface to remove deformation and reveal structure details and subsequently examining the prepared surface under a reflected light microscope.

PROCEDURE:-

(1) Selection of specimen:-

It is essential that the specimen would be selected from that metal which can be taken as representative of whole mass.

(2) Cutting of specimen:-

The specimen may be removed with the help of a saw of trepanning tool, an abrasive wheel etc.

(3) Mounting of specimen:-

The specimen should be mounted in thermoplastic resin or some other low melting point alloy.

(4) Obtaining plus specimen surface:-

This is achieved by using a fairly cross side or by using a motor delivery energy belt.

(5) Intermediate the fine grinding:-

Four grades of abrasive are 220 grit, 320 grit, 400 grit and 600 grit. The 320 grit has a particular shine about 33 micron.

(6) Rough polishing:-

A very small quantity of powder carried on a paste that is oil soluble is placed on the duracloth recovered surface.

(7) Fine polishing:-

A very small quantity of powder carried on a paste that is oil soluble is placed on the duracloth recovered surface. The polishing component is used as alumina powder (Al_2O_3) placed on the valve curved rotating wheel. Distilled water is used as a lubricant. Fine polishing removes fine scratches.



EXPERIMENT NO. 7

OBJECTIVE:-

TO STUDY THE THERMOSETTING PLASTICS.

THEORY:-

Thermosetting plastics are those plastics which are formed into shape under heat and pressure and result in permanently hard product. The heat first softens the material but as additional heat is supplied to the plastic is hardened by a chemical reaction known as polymerization. The reheating does not soften them again and they cannot be reused by remolding.

TYPES OF THERMOSETTING PLASTICS

- (a) **Phenolic Resins:-** It is obtained by condensation of phenol with formaldehyde in the presence of a catalyst. It is also known as Bakelite. It is hard and rigid material & possesses high electrical insulating properties. It is used for manufacturing handles for cooking pots, plugs, switch boards.
- (b) **Amino Resins:-** There are two important amino resins
 - a. Urea Formaldehyde
 - b. Melamine Formaldehyde
- Urea Formaldehyde:-** This thermosetting plastic is manufactured by heating together urea and formaldehyde. Using carefully purified cellulose as filler a wide range of delicately colored molding compositions can be obtained. They have hard surface and high dielectric strength.
- Melamine Formaldehyde :-** The melamine is obtained from calcium carbide. Melamine in combination with formaldehyde as a resin may be combined with various fillers to form molding compound. They have electric arc resistance and high resistance to moisture absorption.
- (c) **Silicon Resins:-** The silicones are synthesized from silicon tetrachloride & organic chloride and polymerized by condensation. They have good resistance to water & are good electrical resistors.
- (d) **Epoxy Resins:-** The epoxy resins are obtained from certain special types of organic chemicals specifically epichlorohydrin and bisphenol. They have good insulating properties and chemical resistance. They are used for making press dies.

EXPERIMENT NO. 8

OBJECTIVE: - To study the creep behavior of a given specimen.

Theory:- Creep may be defined as the process by which plastic flow occurs when a constant stress is applied to a metal for a prolonged period of time.

Creep curve: - Creep curve is a plot between the total creep or % elongation or strain and the time for the entire duration of test. The figure shows a creep curve and marks the various stages of creep.

Diagram:-

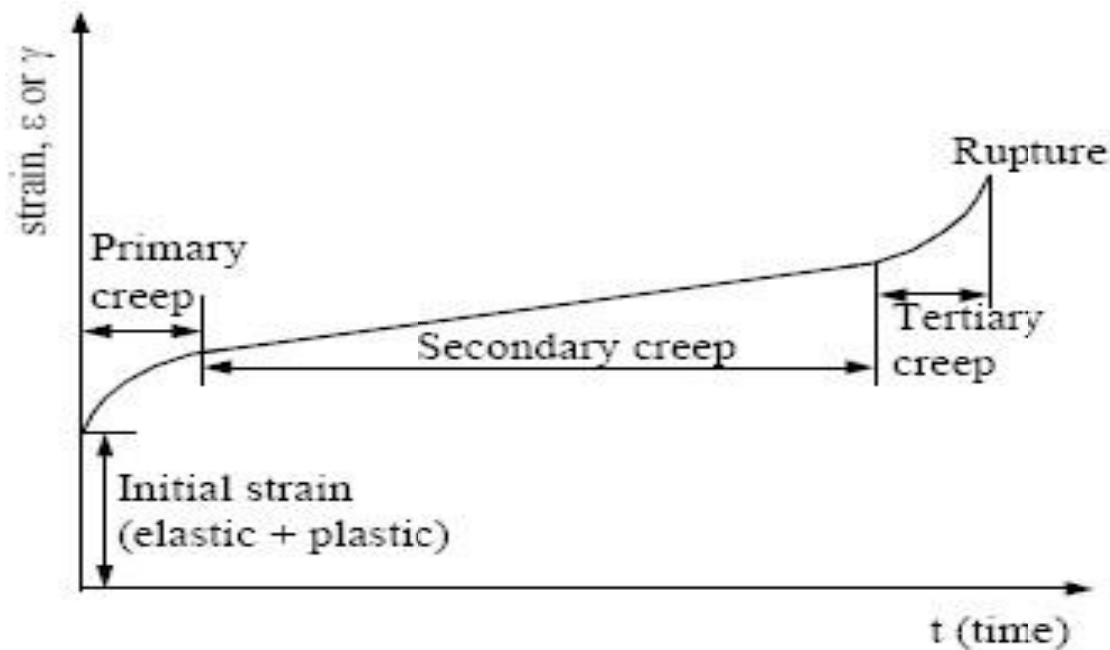

- Primary creep:** - The primary creep is a decreasing creep rate because of the work hardening process resulting from deformation. The primary creep is similar in mechanism to delayed elasticity and is recoverable by unloading the specimen.
- Secondary creep:** - During the secondary creep the deformation continues at a constant rate. During this stage a balance exists between the rate of work hardening and rate of softening because of recovery or recrystallization.
The steady stage creep may be essentially viscous or plastic in character depending upon the stress level and temp.
- Tertiary stage:** - If the stress is sufficiently high and temp. is also high there is a tertiary stage in which the creep rate accelerates until fracture occurs.
Tertiary creep is more probably the result of structural changes occurring in the metal. Void formation and excessive crack formation occurs during this stage.

EXPERIMENT NO:- 9

OBJECTIVE:

TO STUDY THE MECHANISM OF CORROSION.

THEORY

Gradual destruction of metal by chemical or electrochemical attack of its surroundings is known as corrosion. Almost all corrosion involves electrochemical action of some kind. Corrosion of a metal by a liquid or a gas both involve loss of electrons by the metal atoms known as oxidation and gain of electrons by other atoms known as reduction.

Probably the most serious corrosion takes place in the form of electrochemical corrosion.

The factors governing electrochemical corrosion are:-

- Existing potential difference
- Presence of electrolyte
- Completion of a closed circuit
- The maintenance of current through the circuit

MECHANISM OF CORROSION

The bulk of the metallic corrosion is due to the electrolytic action when two different metals or alloys are in electrical contact with each other and are also in common contact with an electrolyte. One metal becomes anodic towards the other and naturally the other metal will work as a cathode. The cathodic action involves two processes namely:-

- (a) Hydrogen evolution:- this type of corrosion occurs in acidic environment such as acid industrial waters.
- (b) Oxygen absorption:- Iron is corroded by a neutral solution of electrolytes in the presence of oxygen, thereby giving rise to rusting of steel. Since iron is anodic to its oxide it will go into solution in the form of ferrous ions

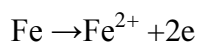

Thus released electrons travel to cathode and take part in the reaction.

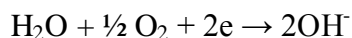

The hydroxyl ions dissolve at the cathode when the Fe^{2+} and OH^{-} ions meet away and following reaction takes place:-

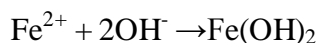

This ferrous oxide is quickly oxidized by atmospheric oxygen to ferric hydroxide. $\text{Fe}(\text{OH})_3$ which is precipitated as a reddish brown substance the main constituent of rust.